

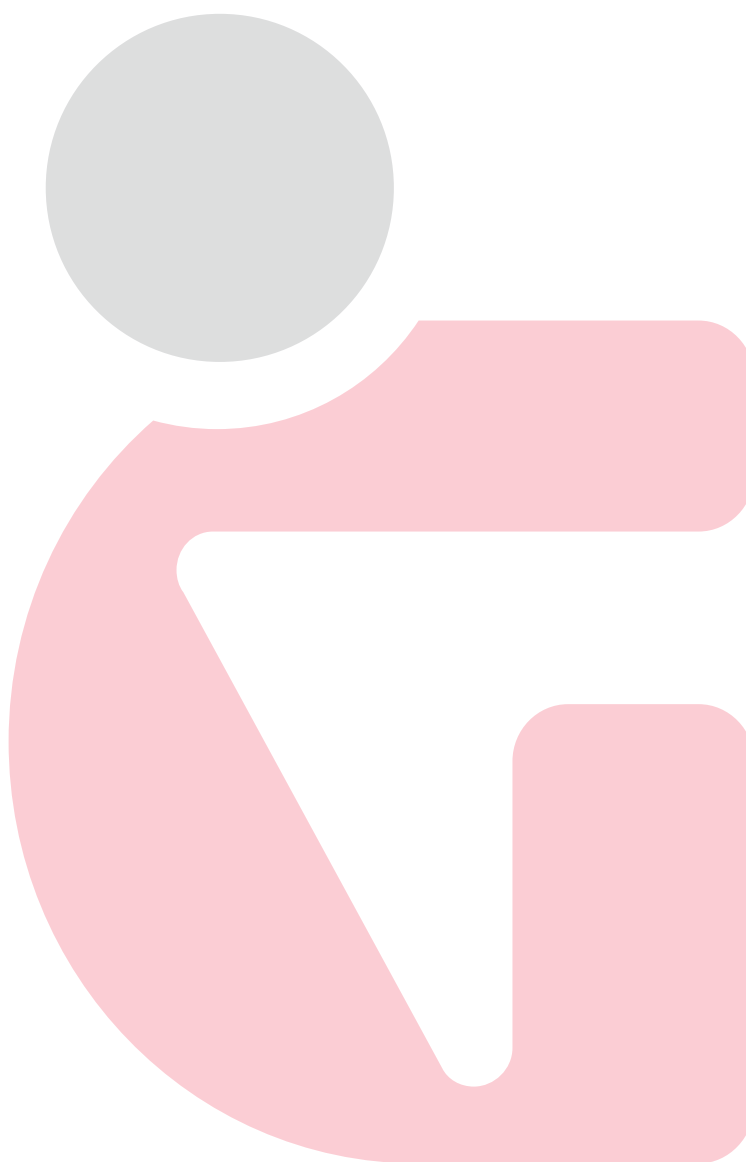

## **Engranajes y cremalleras**



---

**RUEDAS DENTADAS**

---

SERIE **PRM** con moyú pág. 4

---

SERIE **DRM** sin moyú pág. 6

---

SERIE **PRM-P** de poliamida pág. 7

---

SERIE **PCM** cónico tipo A pág. 12

---

---

**PIÑONES TENSORES DE CADENA**

---

SERIE **PT** pág. 9

---

---

**CREMALLERAS**

---

SERIE **CRM** pág. 10

---

SERIE **CRM-P** de poliamida pág. 11

---

Nuestra red comercial pág. 15

---



**Codificación**

e.g.: PRM1,5Z50

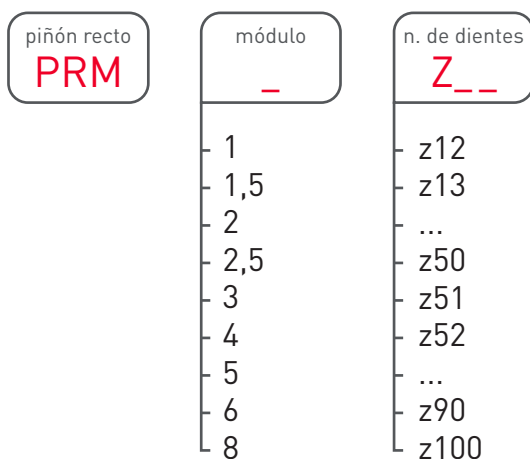

**Plano**

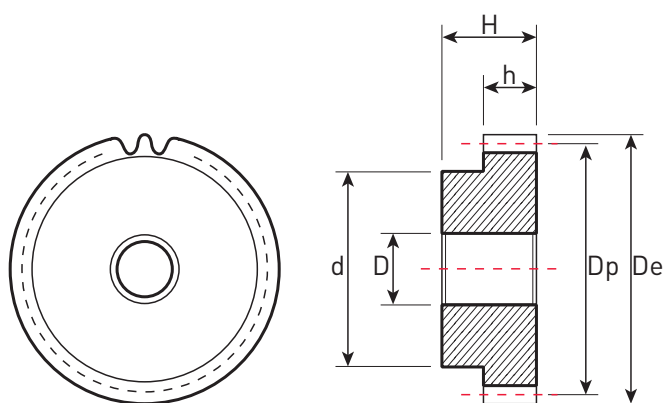

	h mm	H mm
<b>Módulo 1</b>	15	25
<b>Módulo 1,5</b>	17	30
<b>Módulo 2</b>	20	35
<b>Módulo 2,5</b>	25	45
<b>Módulo 3</b>	30	50
<b>Módulo 4</b>	40	60
<b>Módulo 5</b>	50	75
<b>Módulo 6</b>	60	80
<b>Módulo 8</b>	80	110

**Ángulo de presión y material**

20°C, C45E - UNI EN 10083-1.

Z	Módulo 1				Módulo 1,5				Módulo 2			
	De	Dp	d	D	De	Dp	d	D	De	Dp	d	D
12	14	12	9	5	21,0	18,0	14	8	28	24	18	10
13	15	13	10	5	22,5	19,5	14	8	30	26	19	10
14	16	14	10	5	24,0	21,0	17	8	32	28	20	10
15	17	15	12	6	25,5	22,5	18	8	34	30	22	10
16	18	16	13	6	27,0	24,0	20	8	36	32	24	10
17	19	17	14	8	28,5	25,5	20	8	38	34	25	10
18	20	18	15	8	30,0	27,0	20	8	40	36	25	10
19	21	19	15	8	31,5	28,5	20	8	42	38	25	10
20	22	20	16	8	33,0	30,0	25	8	44	40	30	10
21	23	21	16	8	34,5	31,5	25	10	46	42	30	12
22	24	22	18	8	36,0	33,0	25	10	48	44	30	12
23	25	23	18	8	37,5	34,5	25	10	50	46	30	12
24	26	24	20	8	39,0	36,0	25	10	52	48	35	12
25	27	25	20	8	40,5	37,5	25	10	54	50	35	12
26	28	26	20	8	42,0	39,0	30	12	56	52	40	12
27	29	27	20	8	43,5	40,5	30	12	58	54	40	12
28	30	28	20	8	45,0	42,0	30	12	60	56	40	12
29	31	29	20	8	46,5	43,5	30	12	62	58	40	14
30	32	30	20	8	48,0	45,0	30	12	64	60	40	14
31	33	31	25	10	49,5	46,5	35	12	66	62	45	14
32	34	32	25	10	51,0	48,0	35	12	68	64	45	14
33	35	33	25	10	52,5	49,5	35	12	70	66	45	14
34	36	34	25	10	54,0	51,0	35	12	72	68	45	14
35	37	35	25	10	55,5	52,5	35	12	74	70	45	14
36	38	36	25	10	57,0	54,0	35	12	76	72	45	14
37	39	37	25	10	58,5	55,5	40	12	78	74	50	14
38	40	38	25	10	60,0	57,0	40	12	80	76	50	14
39	41	39	25	10	61,5	58,5	40	12	82	78	50	14
40	42	40	25	10	63,0	60,0	40	12	84	80	50	14
41	43	41	30	10	64,5	61,5	50	14	86	82	60	16
42	44	42	30	10	66,0	63,0	50	14	88	84	60	16
43	45	43	30	10	67,5	64,5	50	14	90	86	60	16
44	46	44	30	10	69,0	66,0	50	14	92	88	60	16
45	47	45	30	10	70,5	67,5	50	14	94	90	60	16
46	48	46	30	10	72,0	69,0	50	14	96	92	60	16
47	49	47	30	10	73,5	70,5	50	14	98	94	60	16
48	50	48	30	10	75,0	72,0	50	14	100	96	70	16
49	51	49	30	10	76,5	73,5	50	14	102	98	70	16
50	52	50	30	12	78,0	75,0	50	14	104	100	70	16
51	53	51	40	12	79,5	76,5	60	15	106	102	70	20
52	54	52	40	12	81,0	78,0	60	15	108	104	70	20
53	55	53	40	12	82,5	79,5	60	15	110	106	70	20
54	56	54	40	12	84,0	81,0	60	15	112	108	70	20
55	57	55	40	12	85,5	82,5	60	15	114	110	70	20
56	58	56	40	12	87,0	84,0	60	15	116	112	70	20
57	59	57	40	12	88,5	85,5	60	15	118	114	70	20
58	60	58	40	12	90,0	87,0	60	15	120	116	70	20
59	61	59	40	12	91,5	88,5	60	15	122	118	70	20
60	62	60	40	12	93,0	90,0	60	15	124	120	70	20
61	63	61	50	12	94,5	91,5	70	20	126	122	80	20
62	64	62	50	12	96,0	93,0	70	20	128	124	80	20
63	65	63	50	12	97,5	94,5	70	20	130	126	80	20
64	66	64	50	12	99,0	96,0	70	20	132	128	80	20
65	67	65	50	12	100,5	97,5	70	20	134	130	80	20
66	68	66	50	12	102,0	99,0	70	20	136	132	80	20
67	69	67	50	12	103,5	100,5	70	20	138	134	80	20
68	70	68	50	12	105,0	102,0	70	20	140	136	80	20
69	71	69	50	12	106,5	103,5	70	20	142	138	80	20
70	72	70	50	12	108,0	105,0	70	20	144	140	80	20
72	74	72	50	12	111,0	108,0	80	20	148	144	80	20
75	77	75	50	12								
76	78	76	50	12								
80	82	80	50	12								
90	92	90	50	12								
100	102	100	60	12								

ruedas dentadas cilíndricas con cubo lateral/moyú

serie **PRM**

Z	Módulo 2,5				Módulo 3				Módulo 4				Módulo 5				Módulo 6				Módulo 8							
	De	Dp	d	D	De	Dp	d	D	De	Dp	d	D	De	Dp	d	D	De	Dp	d	D	De	Dp	d	D	De	Dp	d	D
12	35,0	30,0	22	10	42	36	25	12	56	48	35	14	70	60	45	16	84	72	54	20	112	96	56	20				
13	37,5	32,5	25	10	45	39	25	12	60	52	40	14	75	65	50	16												
14	40,0	35,0	28	10	48	42	30	12	64	56	45	14	80	70	55	20	96	84	65	20								
15	42,5	37,5	30	10	51	45	35	12	68	60	45	14	85	75	60	20	102	90	70	20	136	120	90	25				
16	45,0	40,0	32	12	54	48	38	15	72	64	50	15	90	80	65	20	108	96	75	20								
17	47,5	42,5	35	12	57	51	42	15	76	68	50	15	95	85	70	20												
18	50,0	45,0	35	12	60	54	45	15	80	72	50	15	100	90	70	20	120	108	80	20	160	144	100	25				
19	52,5	47,5	35	12	63	57	45	15	84	76	60	15	105	95	70	20												
20	55,0	50,0	40	14	66	60	45	15	88	80	60	15	110	100	80	20	132	120	90	20	176	160	120	30				
21	57,5	52,5	40	14	69	63	45	15	92	84	70	20	115	105	80	20												
22	60,0	55,0	45	14	72	66	50	15	96	88	70	20	120	110	80	25												
23	62,5	57,5	45	14	75	69	50	15	100	92	75	20	125	115	90	25	150	138	110	25								
24	65,0	60,0	45	14	78	72	50	16	104	96	75	20	130	120	90	25	156	144	110	25	208	192	150	30				
25	67,5	62,5	50	14	81	75	60	16	108	100	75	20	135	125	90	25	162	150	110	25	216	200	150	30				
26	70,0	65,0	50	14	84	78	60	16	112	104	75	20	140	130	100	25												
27	72,5	67,5	50	14	87	81	60	16	116	108	75	20	145	135	100	25												
28	75,0	70,0	50	14	90	84	60	16	120	112	75	20	150	140	100	25					240	224	170	30				
29	77,5	72,5	50	14	93	87	60	16	124	116	75	20	155	145	100	25												
30	80,0	75,0	55	16	96	90	60	16	128	120	75	20	160	150	100	25	192	180	110	25	256	240	190	30				
31	82,5	77,5	55	16	99	93	70	20	132	124	80	20																
32	85,0	80,0	55	16	102	96	70	20	136	128	80	20	170	160	110	25												
33	87,5	82,5	55	16	105	99	70	20	140	132	80	20																
34	90,0	85,0	55	16	108	102	70	20	144	136	80	20																
35	92,5	87,5	60	16	111	105	70	20	148	140	80	20																
36	95,0	90,0	60	16	114	108	70	20	152	144	80	20	190	180	110	25												
37	97,5	92,5	60	16	117	111	80	20	156	148	80	20																
38	100,0	95,0	60	16	120	114	80	20	160	152	80	25	200	190	110	30												
39	102,5	97,5	60	16	123	117	80	20	164	156	80	25																
40	105,0	100,0	70	20	126	120	80	20	168	160	80	25	210	200	110	30	252	240	120	25								
41	107,5	102,5	70	20	129	123	90	20																				
42	110,0	105,0	70	20	132	126	90	20					220	210	120	25												
43	112,5	107,5	70	20	135	129	90	20																				
44	115,0	110,0	70	20	138	132	90	20																				
45	117,5	112,5	70	20	141	135	90	20	188	180	80	25																
46	120,0	115,0	70	20	144	138	90	20																				
47	122,5	117,5	80	20	147	141	90	20																				
48	125,0	120,0	80	20	150	144	100	20	200	192	80	25																
49	127,5	122,5	80	20	153	147	100	20																				
50	130,0	125,0	80	20	156	150	100	20	208	200	80	25																
51	132,5	127,5	90	20																								
52	135,0	130,0	90	20																								
53	137,5	132,5	90	20																								
54	140,0	135,0	90	20	168	162	100	20																				
55	142,5	137,5	90	20	171	165	100	20					285	275	120	30												
56	145,0	140,0	100	20	174	168	100	20																				
57	147,5	142,5	100	20	177	171	100	20																				
58	150,0	145,0	100	20																								
59	152,5	147,5	100	20																								
60	155,0	150,0	100	20	186	180	100	20	248	240	100	25	310	300	120	30												
62	160,0	155,0	100	20	192	186	100	20																				
63	162,5	157,5	100	20																								
65	167,5	162,5	100	20	201	195	100	20	268	260	100	25																
67	172,5	167,5	100	20																								
70	180,0	175,0	100	20																								



**Plano**

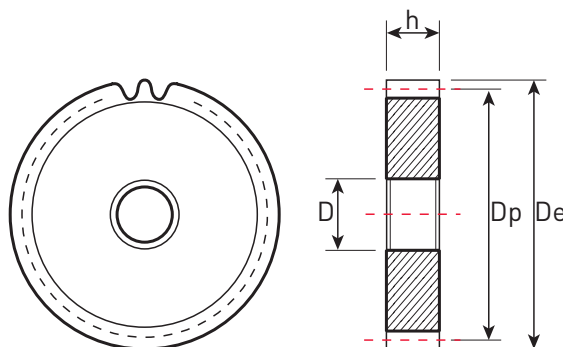

**Codificación**

e.g.: DRM1,5Z70

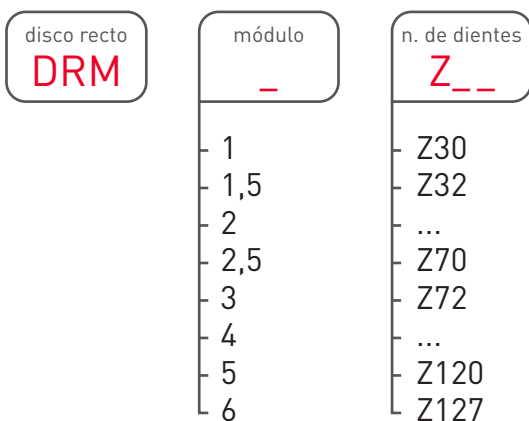

	h mm
<b>Módulo 1</b>	15
<b>Módulo 1,5</b>	17
<b>Módulo 2</b>	20
<b>Módulo 2,5</b>	25
<b>Módulo 3</b>	30
<b>Módulo 4</b>	40
<b>Módulo 5</b>	50
<b>Módulo 6</b>	60

**Ángulo de presión y material**

20°C, C45E - UNI EN 10083-1.

Z	Módulo 1			Módulo 1,5			Módulo 2			Módulo 2,5			Módulo 3			Módulo 4			Módulo 5			Módulo 6		
	De	Dp	D	De	Dp	D	De	Dp	D	De	Dp	D	De	Dp	D	De	Dp	D	De	Dp	D	De	Dp	D
<b>30</b>																						192	180	25
<b>32</b>																			170	160	25	204	192	25
<b>35</b>																			185	175	25			
<b>38</b>																160	152	25	200	190	30	240	220	25
<b>40</b>																168	160	25	210	200	30	252	240	25
<b>45</b>																188	180	25	235	225	30			
<b>48</b>													150	144	25	200	192	25	250	240	30			
<b>50</b>													156	150	25	208	200	25	260	250	30			
<b>52</b>													162	156	25	216	208	25	270	260	30			
<b>55</b>													171	165	25	228	220	25	285	275	30			
<b>57</b>													177	171	25	236	228	25	295	285	30			
<b>58</b>													180	174	25									
<b>60</b>	62	60	12										186	180	25	248	240	25	310	300	30			
<b>65</b>	167,5	162,5	20										201	195	25	268	260	25	335	325	30			
<b>70</b>	72	70	12	180,0	175,0	20							216	210	25	288	280	25	360	350	30			
<b>72</b>	74	72	12	111,0	108,0	20	148	144	20	185,0	180,0	20	222	216	25									
<b>75</b>	77	75	12	115,5	112,5	20	154	150	20	192,5	187,5	20	231	225	25	308	300	25	385	375	30			
<b>76</b>	78	76	12	117,0	114,0	20	156	152	20	195,0	190,0	20	234	228	25	312	304	25	390	380	30			
<b>80</b>	82	80	12	123,0	120,0	20	164	160	20	205,0	200,0	25	246	240	25	328	320	25	410	400	30			
<b>85</b>	87	85	12	130,5	127,5	20	174	170	20	217,5	212,5	25	261	255	25	348	340	25	435	425	30			
<b>90</b>	92	90	12	138,0	135,0	20	184	180	20	230,0	225,0	25	276	270	25	368	360	25	460	450	30			
<b>95</b>	97	95	12	145,5	142,5	20	194	190	20	242,5	237,5	25	291	285	25	388	380	25	485	475	30			
<b>100</b>	102	100	12	153,0	150,0	20	204	200	20	255,0	250,0	25	306	300	25	408	400	25	510	500	30			
<b>110</b>	112	110	12	168,0	165,0	20	224	220	20	280,0	275,0	25	336	330	25	448	440	25	560	550	30			
<b>114</b>	116	114	12	174,0	171,0	20	232	228	20	290,0	285,0	25	348	342	30	464	456	25	580	570	30			
<b>120</b>	122	120	12	183,0	180,0	20	244	240	20	305,0	300,0	25	366	360	30									
<b>127</b>	129	127	12	193,5	190,5	20	258	254	20	322,5	317,5	25	387	381	30									

**Codificación**

e.g.: PRM1,5Z70P

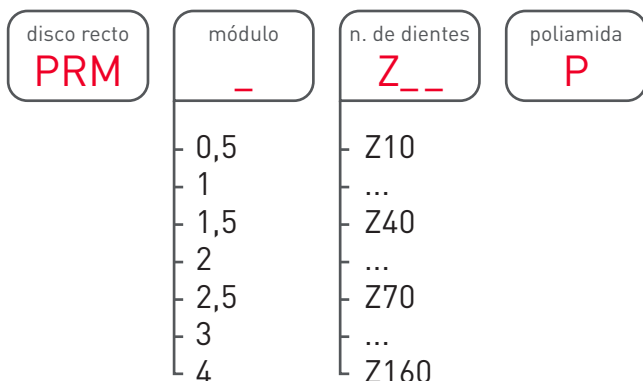
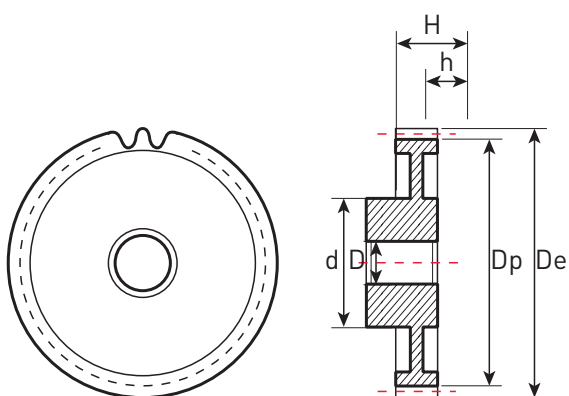
**Plano**

	h mm	H mm
<b>Módulo 0,5</b>	8	16
<b>Módulo 1</b>	15	25
<b>Módulo 1,5</b>	17	30
<b>Módulo 2</b>	20	35
<b>Módulo 2,5</b>	25	45
<b>Módulo 3</b>	30	50
<b>Módulo 4</b>	40	60

Z	Módulo 2,5				Módulo 3			
	De	Dp	d	D	De	Dp	d	D
12	35	30	22	8	42	36	25	12
13					45	39	28	12
14	40	35	22	8	48	42	30	12
15	42,5	37,5	30	10	51	45	30	12
16	45	40	30	10	54	48	40	12
17	47,5	42,5	30	10	57	51	40	12
18	50	45	35	10	60	54	42	12
19	52,5	47,5	35	10	63	57	45	12
20	55	50	35	10	66	60	45	12
21	57,5	52,5	35	16	69	63	45	12
22	60	55	40	16	72	66	45	16
23	62,5	57,5	40	16	75	69	45	16
24	65	60	40	16	78	72	45	16
25	67,5	62,5	40	16	81	75	45	16
26	70	65	40	16	84	78	45	16
27	72,5	67,5	40	16	87	81	45	16
28	75	70	40	16	90	84	50	16
29	77,5	72,5	45	16	93	87	50	16
30	80	75	45	16	96	90	50	16
31	82,5	77,5	45	16	99	93	50	16
32	85	80	50	16	102	96	50	16
33	87,5	82,5	50	16				
34	90	85	50	16	108	102	50	16
35	92,5	87,5	50	16	111	105	60	16
36	95	90	50	18	114	108	60	20
37	97,5	92,5	50	18	117	111	60	20
38	100	95	50	18	120	114	60	17
39	102,5	97,5	50	18	123	117	60	20
40	105	100	50	18	126	120	60	20
41					129	123	60	20
42	110	102,5	60	18	132	126	60	20
43	112,5	105	60	18	135	129	60	20
44					138	132	60	20
45	117,5	112,5	60	18	141	135	60	20
46	120	115	60	20	144	138	60	20
47	122,5	117,5	60	20	147	141	60	20
48	125	120	60	20	150	144	60	20
49	127,5	122,5	60	20	153	147	60	20
50	130	125	60	20	156	150	60	20
52	135	130	60	20	162	156	100	20
54	140	135	60	20	168	162	100	20
55	142,5	137,5	60	20	171	165	100	20
57					177	171	60	20
60	155	150	60	20	186	180	100	2
65	167,5	162,5	60	20				
90	230	225	60	2				

Z	Módulo 0,5				Módulo 4			
	De	dp	dm	D	De	dp	dm	D
16					72	64	50	21
18					80	72	60	21
20					88	80	60	18
30	16	15	10	-				
55	28,5	27,5	20	4				
70	36	35	20	4				

**Ángulo de presión y material**

20°C, nylon 6FV 30.

ruedas dentadas cilíndricas de poliamida

serie **PRM-P**

Z	Módulo 1				Módulo 1,5				Módulo 2			
	De	Dp	d	D	De	Dp	d	D	De	Dp	d	D
10	12	10	12	-								
12	14	12	9	4	21	18	14	5	28	24	18	8
13	15	13	10	4	22,5	19,5	16	5	30	26	18	8
14	16	14	10	4	24	21	16	5	32	28	20	8
15	17	15	10	4	25,5	22,5	18	5	34	30	22	8
16	18	16	13	5	27	24	18	5	36	32	25	8
17	19	17	14	5	28,5	25,5	20	6	38	34	25	8
18	20	18	14	5	30	27	20	6	40	36	30	10
19	21	19	14	5	31,5	28,5	20	8	42	38	30	10
20	22	20	16	5	33	30	25	8	44	40	30	10
21	23	21	16	5	34,5	31,5	25	8	46	42	30	10
22	24	22	18	5	36	33	28	8	48	44	30	10
23	25	23	18	6	37,5	34,5	28	8	50	46	35	10
24	26	24	20	6	39	36	28	8	52	48	35	10
25	27	25	20	6	40,5	37,5	30	8	54	50	35	10
26	28	26	22	6	42	39	30	8	56	52	40	14
27	29	27	22	6	43,5	40,5	30	8	58	54	40	14
28	30	28	22	6	45	42	30	8	60	56	40	14
29	31	29	25	6	46,5	43,5	30	8	62	58	40	14
30	32	30	25	6	48	45	35	12	64	60	40	14
31	33	31	25	6	49,5	46,5	35	12	66	62	40	14
32	34	32	25	6	51	48	35	12	68	64	45	16
33	35	33	25	6	52,5	49,5	35	12	70	66	45	16
34	36	34	30	8	54	51	35	12	72	68	45	16
35	37	35	30	8	55,5	52,5	35	12	74	70	45	16
36	38	36	30	8	57	54	35	12	76	72	50	16
37	39	37	30	8	58,5	55,5	35	16	78	74	50	16
38	40	38	30	8	60	57	35	16	80	76	50	16
39	41	39	30	8	61,5	58,5	35	16	82	78	50	16
40	42	40	30	8	63	60	40	16	84	80	50	16
41	43	41	30	8	64,5	61,5	40	16	86	82	50	16
42	44	42	35	10	66	63	45	16	88	84	50	16
43	45	43	35	10	67,5	64,5	45	16	90	86	50	16
44	46	44	35	10	69	66	45	16	92	88	50	16
45	47	45	35	10	70,5	67,5	45	16	94	90	50	16
46					72	69	45	16	96	92	60	16
47	49	47	35	10	73,5	70,5	45	16	98	94	60	16
48	50	48	35	10	75	72	45	16	100	96	60	16
49	51	49	35	10					102	98	60	16
50	52	50	35	10	78	75	45	16	104	100	60	20
51					79,5	76,5	50	20	106	102	60	20
52	54	52	35	14	81	78	50	20	108	104	60	20
53					82,5	79,5	50	20	110	106	60	20
54	56	54	35	14	84	81	50	20	112	108	60	20
55	57	55	35	14	85,5	82,5	50	20	114	110	60	20
56	58	56	35	14					116	112	60	20
57									118	114	60	20
58	60	58	35	14					120	116	60	20
59									122	118	60	20
60	62	60	40	14	93	90	55	20	124	120	60	20
61									126	122	60	20
62	64	62	40	14					128	124	60	20

Z	Módulo 1				Módulo 1,5				Módulo 2			
	De	Dp	d	D	De	Dp	d	D	De	Dp	d	D
63					97,5	94,5	60	20	130	126	60	20
64	66	64	40	14					132	128	60	20
65	67	65	40	20	100,5	97,5	60	20	134	130	60	20
66	68	66	40	20					136	132	60	20
67									138	134	60	20
68									140	136	60	20
69									142	138	60	20
70	72	70	40	20	108	105	60	20	144	140	60	20
71	73	71	40	20					146	142	60	20
72	74	72	40	20					148	144	60	20
73	75	73	50	20					150	146	60	20
74	76	74	40	20					152	148	60	20
75	77	75	50	20	115,5	112,5	60	20	154	150	60	20
76									156	152	60	20
77	79	77	50	20					158	154	60	20
78									160	156	60	20
79									162	158	60	20
80	82	80	50	20	123	120	60	20	164	160	60	20
81									166	162	60	20
82									168	164	60	20
83									170	166	60	20
84									172	168	60	20
85	87	85	50	20	130,5	127,5	60	20	174	170	60	20
86									176	172	60	20
87									178	174	60	20
88	90	88	50	20					180	176	60	20
89									182	178	60	20
90	92	90	50	20	138	135	60	20	184	180	60	20
91									186	182	60	20
92					141	138	60	20	188	184	60	20
93									190	186	60	20
94									192	188	60	20
95	97	95	50	20	145,5	142,5	60	20	194	190	60	20
96									196	192	60	25
97									198	194	60	25
98									200	196	60	20
99									202	198	60	20
100	102	100	50	20	153	150	60	20	204	200	60	30
102					156	153	60	20				
104	106	104	50	20	159	156	60	20				
105									214	210	60	30
110	112	110	50	20	168	165	60	20				
112									228	224	60	25
114					174	171	60	20				
120	122	120	50	20	183	180	60	20				
126									256	210	60	25
127	129	127	50	20								
130	132	130	50	20								
138	140	138	50	20								
140	142	140	50	20								
150	152	150	50	20								
160	162	160	50	25								



Nuestros piñones tensores con rodamiento de bolas se suministran "listos para montar". Están compuestos por una rueda dentada montada sobre un rodamiento de bolas con doble blindaje de protección, lo que garantiza una alta resistencia a la rotura y al desgaste. El rodamiento no requiere mantenimiento.

Las ruedas están fabricadas en acero C45 y están dentadas de acuerdo con las normas DIN 8187 e ISO 606. El rodamiento de bolas puede operar a una temperatura de  $-20^{\circ}\text{C}$  a  $+120^{\circ}\text{C}$ .

**Plano**

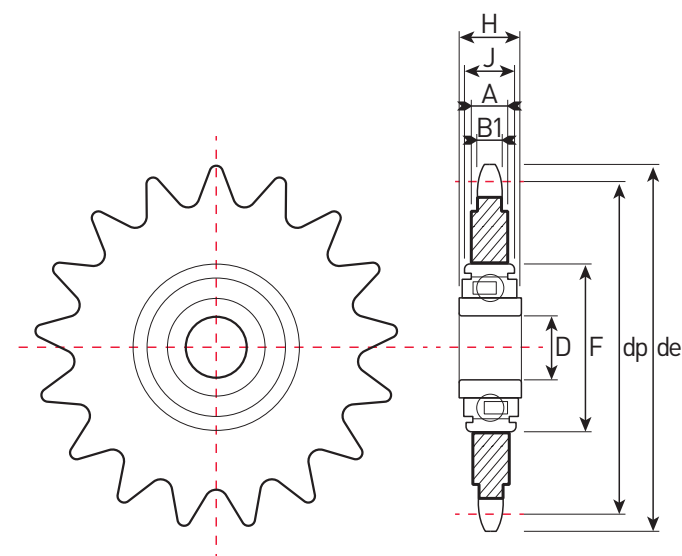

**Codificación**

e.g.: PT5Z17

piñón tensor <b>PT</b>	paso - C _	n. de dientes <b>Z</b> __
	2	Z23
	3	Z21
	4	...
	5	Z17
	6	...
	8	Z13
	10	Z12

Referencia	C	Paso Pulgadas	Z	ISO	De	Dp	B1	A	D	F	H	J	Peso Kg
<b>PT2Z23</b>	<b>2</b>	8 x 1/8"	<b>23</b>	05B-1	62,2	58,75	2,8	7,0	16 <sup>+0,26</sup> <sub>+0,13</sub>	40	18,3	12	0,13
<b>PT3Z21</b>	<b>3</b>	3/8" x 7/32"	<b>21</b>	06B-1	67,6	63,91	5,3	5,3	16 <sup>+0,26</sup> <sub>+0,13</sub>	40	18,3	12	0,15
<b>PT3Z22</b>	<b>3</b>	3/8" x 7/32"	<b>22</b>	06B-1	70,6	66,93	5,3	5,3	16 <sup>+0,26</sup> <sub>+0,13</sub>	40	18,3	12	0,16
<b>PT4Z14</b>	<b>4</b>	1/2" x 5/16"	<b>14</b>	08B-1	61,9	57,07	7,2	7,2	16 <sup>+0,26</sup> <sub>+0,13</sub>	40	18,3	12	0,13
<b>PT4Z16</b>	<b>4</b>	1/2" x 5/16"	<b>16</b>	08B-1	69,9	65,10	7,2	7,2	16 <sup>+0,26</sup> <sub>+0,13</sub>	40	18,3	12	0,17
<b>PT4Z18</b>	<b>4</b>	1/2" x 5/16"	<b>18</b>	08B-1	78,0	73,14	7,2	7,2	16 <sup>+0,26</sup> <sub>+0,13</sub>	40	18,3	12	0,22
<b>PT5Z14</b>	<b>5</b>	5/8" x 3/8"	<b>14</b>	10B-1	78,2	71,34	9,1	9,1	16 <sup>+0,26</sup> <sub>+0,13</sub>	40	18,3	12	0,23
<b>PT5Z15</b>	<b>5</b>	5/8" x 3/8"	<b>15</b>	10B-1	83,2	76,36	9,1	9,1	16 <sup>+0,26</sup> <sub>+0,13</sub>	40	18,3	12	0,27
<b>PT5Z17</b>	<b>5</b>	5/8" x 3/8"	<b>17</b>	10B-1	93,3	86,39	9,1	9,1	16 <sup>+0,26</sup> <sub>+0,13</sub>	40	18,3	12	0,36
<b>PT6Z13</b>	<b>6</b>	3/4" x 7/16"	<b>13</b>	12B-1	87,8	79,59	11,1	11,1	16 <sup>+0,26</sup> <sub>+0,13</sub>	40	18,3	12	0,34
<b>PT6Z15</b>	<b>6</b>	3/4" x 7/16"	<b>15</b>	12B-1	99,8	91,63	11,1	11,1	16 <sup>+0,26</sup> <sub>+0,13</sub>	40	18,3	12	0,47
<b>PT8Z12</b>	<b>8</b>	1" x 17,02"	<b>12</b>	16B-1	109,7	98,14	16,2	16,2	20 <sup>+0,10</sup> <sub>-0</sub>	47	17,7	14	0,72
<b>PT10Z13</b>	<b>10</b>	1" 1/4 x 3/4"	<b>13</b>	20B-1	147,7	132,67	18,5	18,5	25 <sup>+0,10</sup> <sub>-0</sub>	52	21,0	15	1,64

Plano

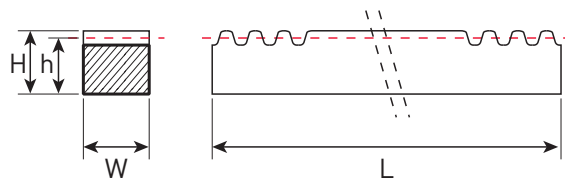

Ángulo de presión y material

20°C, C45E - UNI EN 10083-1.

Referencia	Módulo	h mm	H x W mm	Peso kg			
				L 500 mm	L 1000 mm	L 2000 mm	L 3000 mm
<b>CRM1</b>	<b>1</b>	14,0	15 x 15	0,820	1,500	3,100	4,900
<b>CRM1,5</b>	<b>1,5</b>	15,5	17 x 17	1,000	2,000	4,000	6,100
<b>CRM2</b>	<b>2</b>	18,0	20 x 20	1,400	2,700	5,400	8,400
<b>CRM2,5</b>	<b>2,5</b>	22,5	25 x 25	2,100	4,300	8,600	11,900
<b>CRM3</b>	<b>3</b>	27,0	30 x 30	3,100	6,300	12,500	18,600
<b>CRM4(22X22)</b>	<b>4</b>	18	22 x 22	1,400	3,250	6,800	-
<b>CRM4(25X25)</b>	<b>4</b>	21,0	25 x 25	1,800	3,650	7,300	10,900
<b>CRM4(30X30)</b>	<b>4</b>	26,0	30 x 30	3,050	6,000	11,900	18,100
<b>CRM4(40X40)</b>	<b>4</b>	36,0	40 x 40	5,500	11,100	22,000	31,300
<b>CRM5</b>	<b>5</b>	45,0	50 x 50	8,300	17,500	34,600	45,300
<b>CRM6</b>	<b>6</b>	54	60 x 60	12,650	25,000	51,000	-
<b>CRM8</b>	<b>8</b>	72,0	80 x 80	22,400	45,000	90,000	-

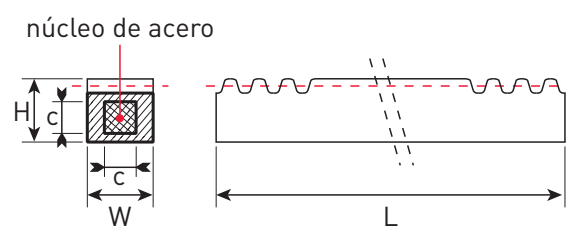
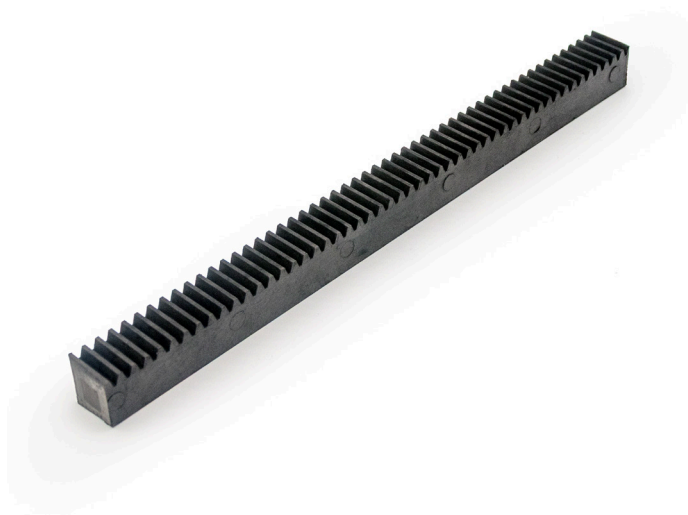
**Plano**

**Ángulo de presión y material**

20°C, C45E - UNI EN 10083-1, nylon 6FV 30.

Referencia	Módulo	H x W mm	C x C mm	L mm				
<b>CRM1P</b>	<b>1</b>	15 x 15	8 x 8	-	350	-	-	-
<b>CRM1,5P</b>	<b>1,5</b>	17 x 17	8 x 8	250	-	-	565,2	-
<b>CRM2P</b>	<b>2</b>	20 x 20	10 x 10	250	-	-	565,2	-
<b>CRM3P</b>	<b>3</b>	30 x 30	15 x 15	250	-	500	-	1000
<b>CRM4P</b>	<b>4</b>	28 x 20	10 x 10	-	-	-	-	1000

**Codificación**

e.g.: PCM1Z16(1:1)

par cónico <b>PCM</b>	módulo M _	n. de dientes <b>Z__</b>	unitario/par _
	1,5	Z16	(1:1)
	2	Z20	16/16
	2,5	Z22	16/32
	3	Z25	16/48
	3,5	Z30	16/64
	4	Z32	
	4,5	Z48	
	5	Z64	



**Ángulo de presión y material**

20°C, C45E, UNI EN 10083-1.

**Relación 1:1**

M	Z	De	Dp	H	F	d	D	V	L	Lm	S
1,5	16	26,1	24,0	18,9	6	20,3	8	7,10	16,9	12,00	2,0
	20	32,1	30,0	20,0	10	22,0	10	7,40	18,0	8,50	2,0
	22	35,1	33,0	20,0	10	25,0	10	8,75	18,0	8,25	2,0
	25	39,6	37,5	23,0	10	28,0	10	11,09	21,0	12,00	2,0
30	47,1	45,0	25,0	12	30,0	12	13,35	22,5	12,00	2,5	
2	16	34,8	32,0	23,5	8	25,3	10	9,50	20,5	14,00	3,0
	20	42,8	40,0	25,0	12	32,0	10	10,78	22,0	12,00	3,0
	22	46,8	44,0	25,0	12	36,0	10	12,70	22,0	11,70	3,0
	25	52,8	50,0	28,0	14	40,0	12	14,28	25,0	12,30	3,0
30	62,8	60,0	30,0	16	50,0	12	17,78	27,0	12,80	3,0	
2,5	16	43,5	40,0	28,1	10	30,3	12	11,90	24,6	15,00	3,5
	20	53,5	50,0	30,5	12	40,0	12	15,43	27,0	16,00	3,5
	22	58,5	55,0	30,5	12	45,0	12	17,80	27,0	15,90	3,5
	25	66,0	62,5	33,5	15	50,0	15	19,48	30,0	16,00	3,5
30	78,5	75,0	35,5	18	55,0	15	23,63	32,0	16,00	3,5	
3	16	52,2	48,0	31,7	12	40,3	15	14,30	27,7	18,00	4,0
	20	64,2	60,0	35,0	18	45,0	15	16,00	31,0	13,60	4,0
	22	70,2	66,0	35,0	18	50,0	15	19,00	31,0	13,00	4,0
	25	79,2	75,0	38,0	20	55,0	15	22,00	34,0	16,00	4,0
30	94,2	90,0	40,0	22	60,0	20	28,00	36,0	17,00	4,0	
3,5	16	60,9	56,0	36,4	14	45,3	15	16,60	31,9	20,00	4,5
	20	74,9	70,0	40,5	22	55,0	15	18,13	36,0	17,00	4,5
	22	81,9	77,0	40,5	22	60,0	15	21,50	36,0	18,00	4,5
	25	92,4	87,5	43,5	26	65,0	20	23,97	39,0	18,00	4,5
30	109,9	105,0	48,0	30	70,0	20	30,02	43,5	19,00	4,5	
4	16	69,6	64,0	44,3	15	50,3	15	19,70	39,3	25,00	5,0
	20	85,6	80,0	43,0	25	60,0	18	20,74	38,0	18,00	5,0
	22	93,6	88,0	43,0	25	65,0	18	24,70	38,0	18,00	5,0
	25	105,6	100,0	45,0	28	70,0	20	28,50	40,0	18,00	5,0
30	125,6	120,0	48,0	32	80,0	25	35,67	43,0	16,00	5,0	
4,5	16	78,3	72,0	46,3	18	55,3	18	21,70	40,3	25,00	6,0
	20	96,3	90,0	48,0	28	65,0	20	23,41	42,0	18,00	6,0
	22	105,3	99,0	48,0	28	70,0	20	27,80	42,0	18,00	6,0
	25	118,8	112,5	50,0	32	75,0	20	31,76	44,0	18,00	6,0
30	141,3	135,0	53,0	35	90,0	25	40,82	47,0	17,00	6,0	
5	16	87,0	80,0	48,9	18	60,3	20	25,10	42,4	24,19	6,5
	20	107,1	100,0	50,5	30	70,0	20	26,86	44,0	18,50	6,5
	22	117,1	110,0	50,5	30	80,0	20	31,70	44,0	18,50	6,5
	25	132,1	125,0	53,5	34	90,0	20	36,36	47,0	18,00	6,5
30	157,1	150,0	56,5	38	110,0	30	45,97	50,0	18,00	6,5	

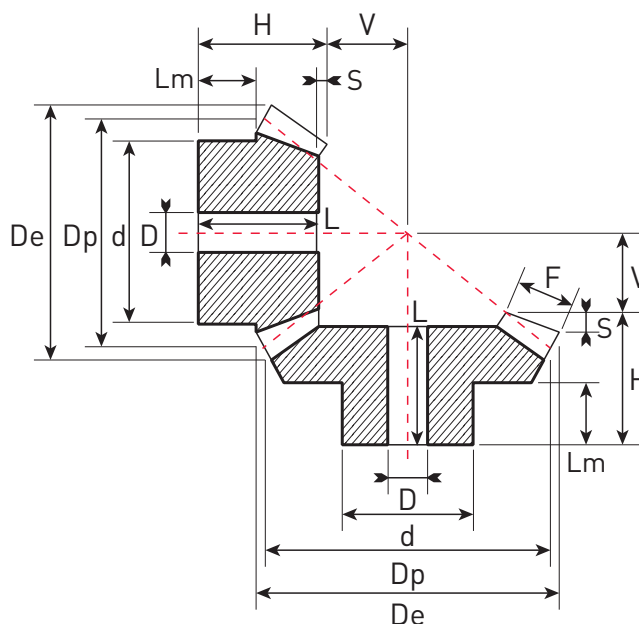

**Relación 1:2**

M	Z	De	Dp	H	F	d	D	V	L	Lm	S
1,5	16	26,7	24	19,5	8	21	10	16,33	18	11,3	1,5
	32	49,3	48	20,0	8	32	12	7,45	17	10,0	3,0
2	16	35,6	32	23,0	10	26	10	22,41	21	12,2	2,0
	32	65,8	64	25,0	10	40	12	10,21	21	10,0	4,0
2,5	16	44,4	40	27,5	12	34	12	28,38	25	14,4	2,5
	32	82,2	80	26,0	12	50	15	13,10	20	10,0	6,0
3	16	53,4	48	28,0	15	40	15	33,64	25	11,6	3,0
	32	98,7	96	30,0	15	60	15	15,31	24	10,0	6,0
3,5	16	62,3	56	33,5	18	48	15	38,83	30	14,4	3,5
	32	115,1	112	31,0	18	70	20	17,77	24	10,0	7,0
4	16	71,1	64	36,0	20	50	20	44,81	32	13,4	4,0
	32	131,6	128	32,0	20	80	20	20,42	24	10,0	8,0
4,5	16	80,1	72	39,5	22	60	20	51,00	35	15,4	4,5
	32	148,0	144	36,0	22	90	25	23,21	27	10,0	9,0
5	16	88,9	80	50,0	25	60	20	56,06	45	21,1	5,0
	32	164,5	160	38,0	25	100	25	25,52	28	10,0	10,0

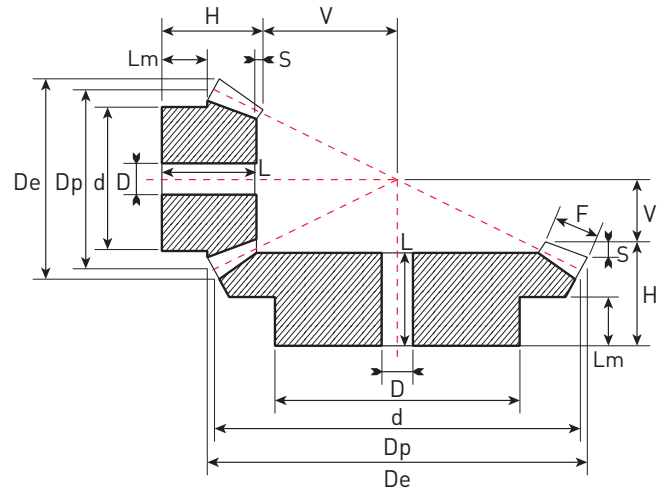

**Relación 1:3**

M	Z	De	Dp	H	F	d	D	V	L	Lm	S
1,5	16	26,9	24	24,0	12	20	10	24,30	23,0	11,95	1,0
	48	72,9	72	20,0	12	50	15	7,27	17,0	10,00	3,0
2	16	35,8	32	28,5	15	26	12	33,26	27,0	12,40	1,5
	48	97,3	96	23,0	15	60	15	9,90	19,0	10,00	4,0
2,5	16	44,7	40	32,0	18	32	12	42,41	30,0	13,00	2,0
	48	121,6	120	26,0	18	70	20	13,23	21,0	10,00	5,0
3	16	53,7	48	32,0	18	40	15	54,25	30,0	12,10	2,0
	48	145,9	144	29,0	18	80	20	16,20	23,0	10,00	6,0
3,5	16	62,6	56	38,0	22	48	15	62,29	35,5	15,00	2,5
	48	170,2	168	31,0	22	90	20	18,48	24,0	10,00	7,0
4	16	71,6	64	41,5	25	55	20	71,23	38,5	15,20	3,0
	48	194,5	192	33,0	25	100	22	21,20	25,0	10,00	8,0
4,5	16	80,6	72	53,0	28	60	20	80,27	50,0	23,40	3,0
	48	218,6	216	49,0	28	100	25	23,93	40,0	18,00	9,0
5	16	89,5	80	60,0	35	60	20	85,61	57,0	22,50	3,0
	48	243,1	240	50,0	35	150	28	25,45	40,0	20,00	10,0

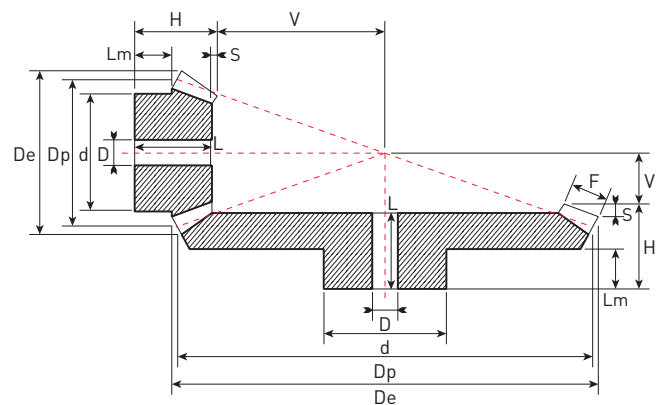

**Relación 1:4**

M	Z	De	Dp	H	F	d	D	V	L	Lm	S
1,5	16	26,9	24	25,0	12	18	10	36,02	24,0	12,20	1,0
	64	96,7	96	22,0	12	70	15	8,53	19,0	10,00	3,0
2	16	35,9	32	24,0	15	25	12	49,07	23,0	8,17	1,0
	64	129,0	128	24,0	15	80	20	10,83	20,0	10,00	4,0
2,5	16	44,9	40	30,5	18	30	15	61,99	29,0	11,70	1,5
	64	161,2	160	29,0	18	90	20	13,77	24,0	10,00	5,0
3	16	53,8	48	34,0	22	40	15	74,05	32,0	11,00	2,0
	64	193,5	192	30,0	22	100	20	16,41	24,0	10,00	6,0
3,5	16	62,8	56	45,0	25	48	15	87,13	43,0	19,10	2,0
	64	225,7	224	50,0	25	100	25	19,32	43,0	22,00	7,0
4	16	71,7	64	50,0	30	50	20	98,21	48,0	18,50	2,0
	64	257,9	256	50,0	30	120	28	21,72	42,0	20,00	8,0
4,5	16	80,7	72	53,0	32	55	20	112,08	50,5	19,00	2,5
	64	290,1	288	53,0	32	130	30	24,83	44,0	23,00	9,0
5	16	89,7	80	58,0	35	60	20	125,06	55,5	20,60	2,5
	64	322,4	320	58,0	35	150	30	27,65	48,0	25,00	10,0

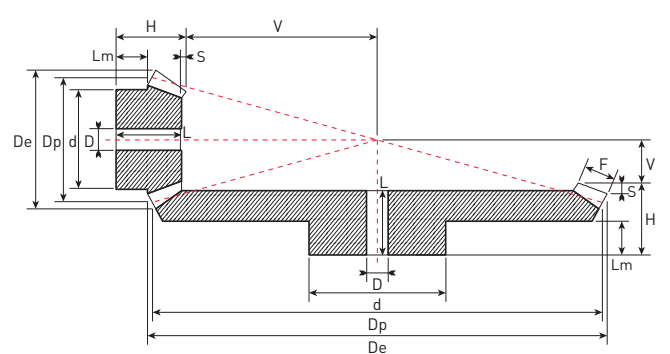

## Productos y servicios relacionados



Guías de recirculación de bolas  
Accesorios de guías, guías protegidas

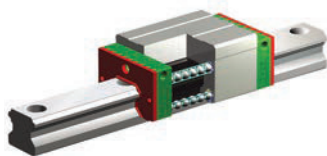

Guías de recirculación con jaula



Guías monorraíl



Guías con encoder



Reductor planetarios de precisión



Cremallera de precisión



Soportes de husillos



Mesas lineales



Tuercas y husillos a bolas



Tuercas dobles



Tuercas rotativas



Actuadores lineales



Tuercas de precisión



Rodamientos de rodillos cruzados



Torquemotores



Reductores armónicos

**1**  
**GAES - CENTRAL**  
 Pº Ubarburu 58 - Pol. 27  
 20014 San Sebastián (Guipúzcoa)  
 Tel. 943 445 777  
 comercial@gaessa.com

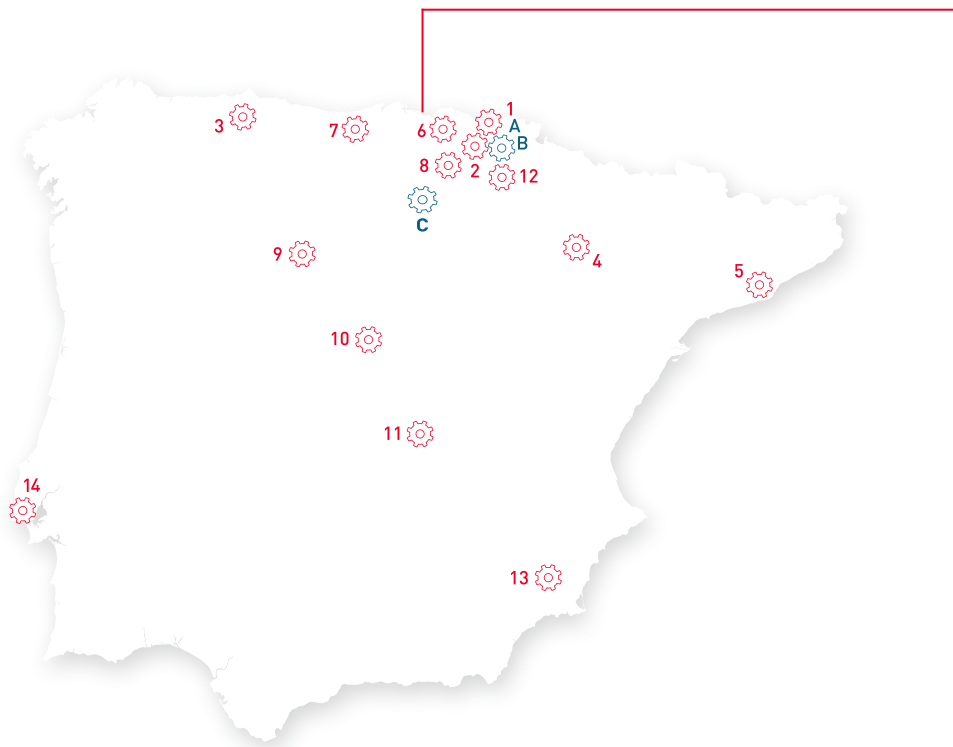

**2**  
**GAES - GUIPÚZCOA**  
 Pol. Ittola 5C - Barrio Salbatore  
 20200 Beasain (Guipúzcoa)  
 Tel. 943 881 317  
 beasain@gaessa.com

**3**  
**GAES - ASTURIAS**  
 C/ Peña Redonda NºR43 - P. I. Silvota  
 33192 Llanera (Asturias)  
 Tel. 985 232 997  
 oviedo@gaessa.com

**4**  
**GAES - ZARAGOZA**  
 C/ Sisallo 13 Nave 2 - P. Empresarium  
 50720 La Cartuja (Zaragoza)  
 Tel. 976 523 511  
 zaragoza@gaessa.com

**5**  
**GAES - CATALUÑA**  
 Av. Olof Palme, 6  
 08840 Viladecans (Barcelona)  
 Tel. 637 587 389  
 paco.arias@gaessa.com

**6**  
**GAES VIMECA**  
 Pol. Ind. Aperribai  
 48960 Galdakao (Vizcaya)  
 Tel. 944 267 510  
 bilbao@gaessa.com

**7**  
**GAES VIMECA**  
 C/ Bonifacio del Castillo 15-17  
 39300 Torrelavega (Cantabria)  
 Tel. 664682271  
 cantabria@gaessa.com

**8**  
**RODALSA**  
 C/ Zurrupitieta, 26 - Pab.28 - P. I. Jundiz  
 01015 Vitoria (Álava)  
 Tel. 945 289 395  
 rodalsa@infonegocio.com

**9**  
**RODALSA**  
 C/ Oro 42, 2º Iz. Of 11 - P. San Cristóbal  
 47012 Valladolid (Valladolid)  
 Tel. 983 081 769  
 rodalsa@infonegocio.com

**10**  
**GAES MICROSYSTEM MOTION**  
 C. del Mar Mediterráneo 2, Nave 5  
 28830 S. Fernando de Henares (Madrid)  
 Tel. 919 199 139  
 info@gaesmicrosystem.com

**11**  
**GAES NAWERS MOTION**  
 C/ Ruidera - Esq. Valle de Alcludia  
 13700 Tomelloso (Ciudad Real)  
 Tel. 926 501 800  
 info@gaesnawers.com

**12**  
**SOLTECNA**  
 C/ Ezponda nº 3 - Pol. Ind. Areta  
 31620 Huarte-Pamplona (Navarra)  
 Tel. 948 361 055  
 soltecna@soltecna.com

**13**  
**GAES Zona Levante**  
 Valencia  
 Tel. 672 241 378  
 ivan.gonzalez@gaessa.com

**14**  
**GAES - PORTUGAL**  
 Lisboa  
 Tel. +351 918 113 097  
 paulo.armada@gaessa.com

Empresas de servicios:

- A TALLER DE MONTAJE & MECANIZADO**
- B TALLERES MECÁNICOS ARATZ**
- C TÉCNICAS MECÁNICAS & DESARROLLO NAVARRA (TEMEDENA)**

Grupo GAES se reserva el derecho de realizar modificaciones en este catálogo sin previo aviso.

